

BlueWater™

Electromagnetic Flowmeter

INSTALLATION, OPERATION AND MAINTENANCE MANUAL

IDS-676-DL
Rev 180510



Contents

1.0 General.....	1
1.1 Measuring System.....	1
1.2 Operating Principle	1
1.3 Application to Magnetic Flow Measurement	1
1.4 System Operation	1
1.5 Construction.....	2
1.5.1 Sensor.....	2
1.5.2 Transmitter	2
1.6 Specifications	3
1.7 Interchangeability	4
1.8 Flow Rates, Dimensions and Weight.....	4
2.0 Pre-Installation.....	5
2.1 Receiving and Inspection	5
2.2 Storage	5
2.3 Return of Equipment.....	5
3.0 Installation	6
3.1 Application Considerations	6
3.2 Site Selection.....	6
3.3 Rotating the Transmitter Display	6
3.4 Grounding	7
3.4.1 Mounting in Unlined Metal Pipes	7
3.4.2 Mounting in Plastic or Lined Pipeline.....	7
3.5 Electrical Connections.....	8
3.5.1 Connecting Power Leads.....	8
3.5.2 Connecting Outputs	9
4.0 Startup Procedure.....	10
5.0 Calibration.....	10
6.0 Maintenance	10
7.0 Troubleshooting.....	11
7.1 General.....	11
7.2 Troubleshooting Chart	11
7.3 Electronics Module Replacement	12

7.4 Replacing the flash memory.....	12
7.5 Replacing the Battery.....	13
8.0 Replacement Parts List.....	13
Appendix 1: Programming the BlueWater Flow Meter	14
A1.1 Show Meter Data.....	15
A1.1.1 Show Meter Data - Screen 1	15
A1.1.2 Show Meter Data - Screen 2	15
A1.2 Configuration of BlueWater Flowmeter	17

1.0 General

1.1 Measuring System

The Sparling BlueWater™ Model FM676 flowmeter is an obstructionless device for measuring the volumetric flow of water in full, closed, pipes. The BlueWater flow meter is ideally suited to irrigation applications. The flowmeter consists of a flanged sensor with a polyurethane, nonmagnetic, liner, sensing electrodes and a measuring transmitter.

1.2 Operating Principle

The operation of the BlueWater flow meter is based on Faraday's Law of Magnetic Induction. An electrically conductive liquid flowing through a magnetic field induces a voltage which is perpendicular to this field and to the direction of the flow. This voltage is proportional to the average flow velocity.

The formula describing Faraday's law reads:

$$E = B \times L \times V$$

Where:

E = Induced voltage

B = Magnetic field intensity (flux density)

L = Distance between the electrodes (pipe diameter)

V = Average flow velocity of liquid

See Figure 1.1.

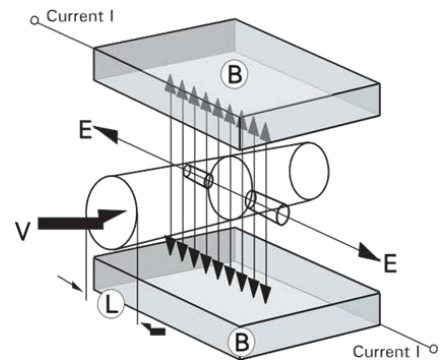

Figure 1.1

1.3 Application to Magnetic Flow Measurement

In a magnetic flowmeter, the liquid acts as a moving conductor as it flows through the pipe. The induced voltage (E) in the liquid is measured by two sensing electrodes mounted opposite each other in the meter sensor. The length of the conductor is equal to the distance between sensing electrodes, which is the internal diameter (D) of the pipe. The flux density is proportional to the coil current (I) times a constant (k). The above formula can be restated as follows:

$$E = I \times k \times D \times V$$

Note that if I is held constant, the induced voltage is directly proportional to the average flow rate (V). This linear relationship is the fundamental relationship governing the BlueWater flow meter.

1.4 System Operation

The BlueWater uses an autozeroing, bipolar, pulsed-DC measuring technique. The circuitry energizes the coil with a current and the signal generated at the electrodes is measured near the end of each measuring cycle to eliminate the capacitive effects of coatings. The impedance eliminates the resistive effects of electrode coatings. The field current alternates to a positive and negative state and the two measured signals are averaged to eliminate the effect of a zero offset-this is the auto-zeroing feature.

1.5 Construction

1.5.1 Sensor

All BlueWater meters are rugged, waterproof assemblies capable of handling a wide range of environmental conditions. The FM676 flow sensor consists of a welded assembly of a 304-stainless steel pipe and two carbon steel flanges. The inside of the pipe is lined with a nonconductive liner of polyurethane, with the coils to generate the magnetic field wrapped around the outside of this pipe. To cover and protect the electrodes and the coil, a steel housing is welded around the outside of the meter.

1.5.2 Transmitter

Integral

The transmitter is housed in a NEMA-4X enclosure mounted on the meter body. The power and signal electrical connections are made in a separate section of the housing which is isolated from the electronics.

Remote

Currently, FM676 BlueWater is unavailable with a remote transmitter



DO NOT MAKE OUTPUT CONNECTIONS WHILE POWER IS APPLIED.

Always disconnect the battery and/or power before making any connections

1.6 Specifications

Power Requirements	7.2 V 19Ah Battery and / or 8 – 36 VDC. When connected to DC power, battery acts as a back up to supplied power.
Wire Size	Power: 14 – 16 AWG Pulse output: 18 AWG
Accuracy	1% of flow rate (1 – 33 fps)
Repeatability	Within $\pm 0.1\%$ full scale
Power	3 mW at lowest sample frequency
Output Signal	Vdc pulse with 12.5/25/50/100 ms on-time, 0-60 Hz max into 100 ohm impedance min.
Minimum Conductivity	5 μ siemens
Velocity Range	0 – 33 fps
Ambient Temp Limits	-40° to 140°F (-40° to 60 °C)
Process Temp	-40° to 180°F (-40° to 80 °C)
Storage Temp Limits	-40° to 140°F (-40° to 60 °C)
Construction	Metering Tube: 304 SS with welded ANSI compliant carbon steel flanges Electrodes: 316 SS Transmitter Housing: Cast Aluminum, NEMA4X Electrical Rating: General Purpose

1.7 Interchangeability

The BlueWater transmitter is designed to be used with any FM676 sensor. Electronics are easy to remove and replace and are interchangeable. Meter identification (Serial Number and Calibration Data) is stored on a flash memory chip independent of transmitter electronics. This provides universal compatibility, eliminating the need for reprogramming when switching modules.

1.8 Flow Rates, Dimensions and Weight

Table 1.8 lists the key dimensions of each size of meter, its shipping weight and the minimum and maximum flow rates.

Table 1.8: BlueWater Dimensions, Weight and Flow Rate

Nominal Size (Inches)	Dimensions (Inches)			Weight lbs	Flow Rates (GPM)		
	Lay Length (A)	Flange (B)	Height (C)		1 fps	3 fps	33 fps
3	6.00	7.50	13.00	48	20	60	664
4	10.24	9.00	14.38	55	35	107	1,182
6	12.27	11.00	17.00	75	85	254	2,800
8	14.24	13.50	19.40	105	145	436	4,800
10	18.18	16.00	22.56	155	236	709	7,800
12	19.68	19.00	25.00	235	333	1,000	11,000
14	21.38	21.00	26.67	365	409	1,227	13,500

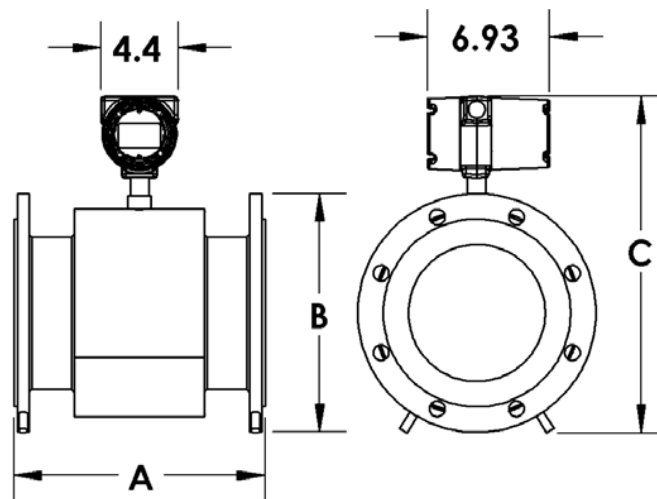

2.0 Pre-Installation

2.1 Receiving and Inspection

When the equipment is received, the outside of the package should be inspected for damage. If any damage or a shortage is found, a notation to that effect should be made on the carrier's delivery receipt.

Visually inspect the sensor and transmitter for damage from rough handling or faulty packaging. If concealed damage is discovered, notify the delivering carrier at once and request an inspection. If inspection is not made, prepare an affidavit stating that you notified the transportation company and that they failed to inspect. Save containers and packaging material.

2.2 Storage

This equipment should be stored in a clean, dry environment. Do not store outside in an unprotected area. Observe the storage temperature requirements.

2.3 Return of Equipment

Obtain an RGA (Returned Goods Authorization) number from the factory prior to returning any materials. The RGA number should be marked on the outside of the package. Failure to obtain authorization will unnecessarily delay any work to be performed at the factory.

3.0 Installation

3.1 Application Considerations

The BlueWater can be used to accurately measure the volumetric flow rate of liquids having a conductivity of at least 5 micromhos/cm.

The presence of entrained air or gases in the process liquid will not prevent meter operation but will produce a positive (+) error equal to the % by volume gas entrainment.

3.2 Site Selection

Select a pipe location that will always be full of liquid. The equipment should be located where the flowmeter will be accessible for adjustment. Provide a minimum of 18" clearance to the electronics enclosure.

The meter may be located in any position from vertical to horizontal. Flow may be in either direction through the meter. When installing in a vertical direction, however, upflow of fluid is preferred to assure a full pipe condition.

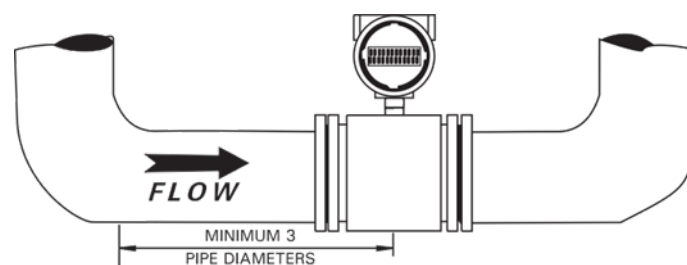

Figure 3.1

Horizontal installation requires that the sensing electrodes be positioned in the horizontal plane. See Figure 3.7.

Provide at least three pipe diameters of straight piping approach between an upstream elbow and the midpoint of the meter. More straight approach should be provided after valves or multiple elbows. Provide at least 10 diameters after expanders or laterals which are of smaller diameter than the line size.

3.3 Rotating the Transmitter Display

The Sparling BlueWater's modular display is designed to allow you to rotate the display in four different orientations. The display assembly can be rotated, at 90° intervals, by removing the two screws circled in Figure 3.3 below, for ease of reading the display.

The display assembly can be replaced in the field without replacing the entire electronics, by following the same procedures as utilized for rotating the display.

3.4 Grounding

DC and AC voltages can be transmitted through conductive fluids which can lead to magnetic flow meter instrument errors. Adequate grounding between the liquid and the instrument is essential to ensure correct flow measurement. Magnetic flow meters should always be grounded at four places:

1. Flowmeter tube,
2. Transmitter
3. Receiving instrument
4. the fluid.

The grounding rings are in continuous contact with the process liquid providing a direct means for grounding electrical noise in the liquid. The electrical noise potential in the process liquid is at a similar level to the electrical ground plane to which the AC power supply ground is connected. This grounding method stabilizes the electrical field within the sensor measuring section permitting accurate flow detection. Grounding resistance must be less than 20 ohms.

3.4.1 Mounting in Unlined Metal Pipes

Mounting in Unlined Metal Pipelines

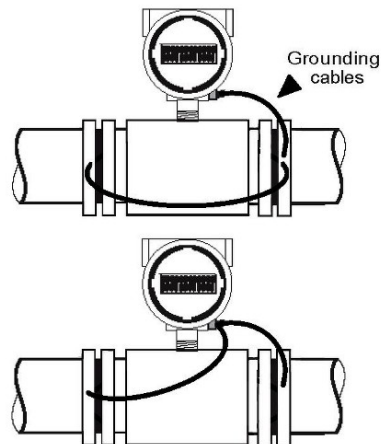

3.4.2 Mounting in Plastic or Lined Pipeline

Mounting in Plastic or Lined Pipeline, or where Conductivity <math>< 20 \text{ micromhos/cm}</math>

EXTERNAL GROUNDING RINGS SHOULD BE INSTALLED ON ANY METER WHERE THERE IS LINED OR NONCONDUCTIVE PIPE

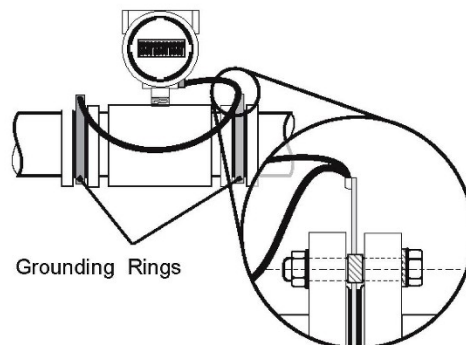

3.5 Electrical Connections

If DC power is to be supplied and / or pulse output is utilized care must be taken to ensure that watertight connections are utilized.

Unscrew the blind cover of the electronics enclosure to gain access to the I/O PCB. Separate 3/4" NPT conduit entrances are provided for power and signal wiring. Conduit connections should follow good practice and should be routed from below the meter. If conduit cannot be routed from below, provide moisture traps and seals to prevent moisture from entering the meter enclosure. See Figure 3.11. Be sure to tighten conduit connections.



Watertight conduit, NEMA-6P fittings and seals are required to maintain the moisture free integrity of all enclosures and electronics in the system. Entry of moisture may void Sparling's warranty. All fittings must conform to NEMA-6P Classifications.

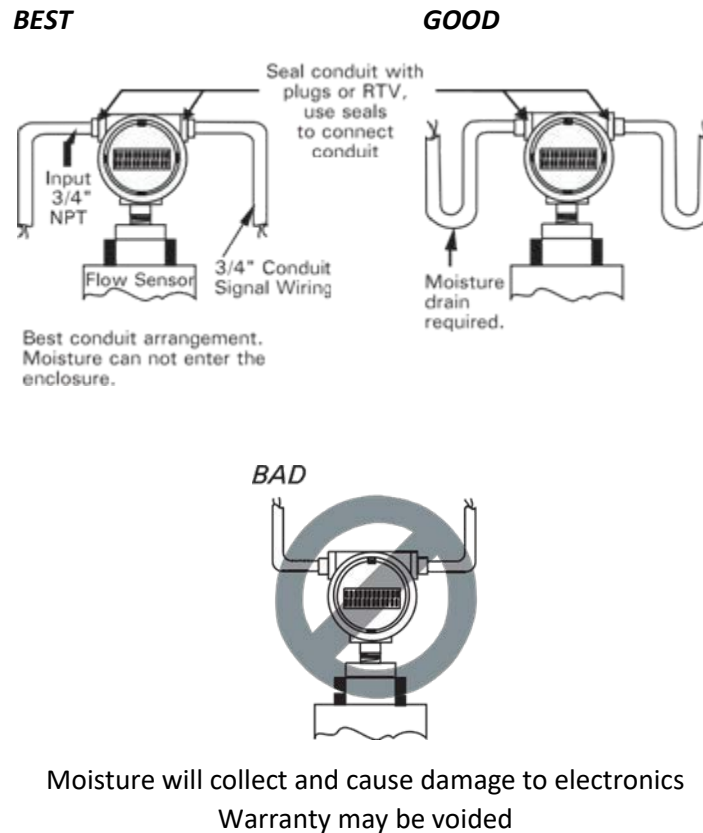

Conduit Connections Figure 3.5

3.5.1 Connecting Power Leads

Connect power leads to the terminal block on the I/O board on the '+ VDC - 8 - 36V' DC terminals.

3.5.2 Connecting Outputs

To connect the outputs, use the connections on the terminal block for 'Totalizer'. Verify that the external load on the outputs is within the limits specified. Calculate the external load by summing the input resistance, including all interconnecting cable. For the BlueWater Pulse output: 100 Ω minimum impedance. Signal cable of 18-22 gauge is normally adequate.

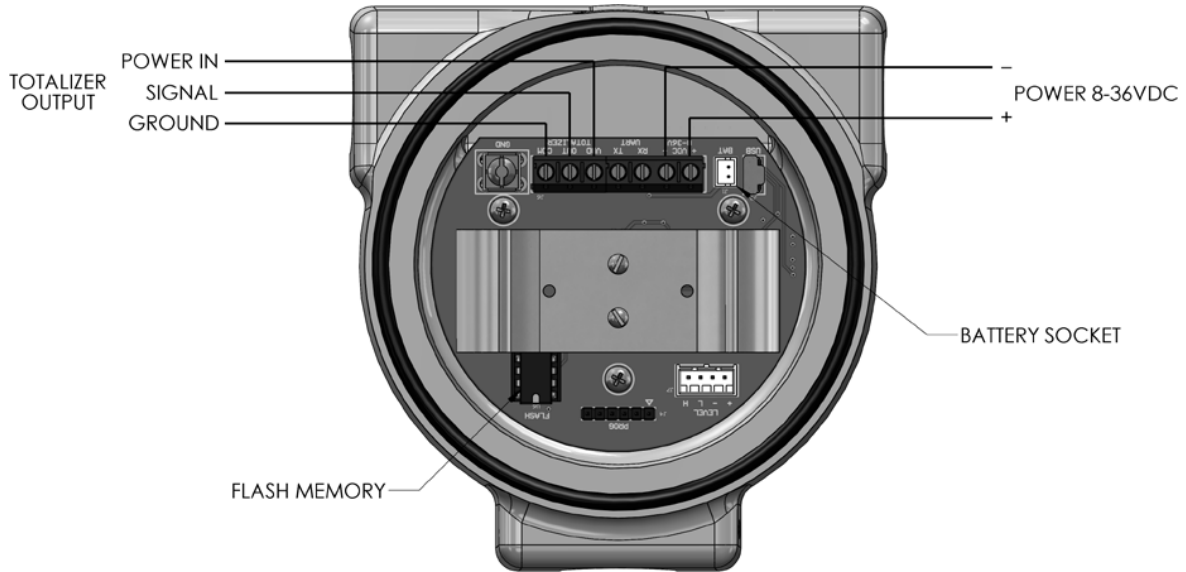

4.0 Startup Procedure

The BlueWater flow meter is shipped with the battery connected, ready to use. There is no set up needed other than the correct installation as described in Section 3. However, the setup of the meter should be verified after installation. Please see Appendix 1 for steps to view meter data.

5.0 Calibration

All flowmeters are calibrated before leaving the factory. No field recalibration is required.

6.0 Maintenance

No routine maintenance is required.

7.0 Troubleshooting

The following sections describe field tests that can be performed on Sparling's magnetic flow meters

7.1 General

Each flowmeter is rigorously tested during production. The final test stage is a wet flow calibration in a Sparling precision primary flow laboratory traceable to the National Institute of Standards and Technology (NIST).

Before troubleshooting, carefully verify the operating conditions of the meter:

1. Verify that the sensor is completely filled with liquid. An empty or partially full sensor will continue to send an erratic flow signal even with no flow.
2. Verify that any flow test comparison is valid before assuming that the meter is in error.
3. If in doubt, verify the conductivity of the liquid to see that it exceeds 5 micromhos/cm.

7.2 Troubleshooting Chart

The following trouble shooting chart should assist in correcting meter malfunction. For additional assistance, contact Technical Support (800) 800-FLOW

1. Erratic Reading (Output Wandering)	<ul style="list-style-type: none">A. Installation<ul style="list-style-type: none">a. Is sensor properly grounded? A good liquid ground is required.b. Empty pipe? Pipe must be full of liquid.c. Air in pipe? De-aerated. Chemical being injected upstream of flowmeter? Change the chemical dosage downstream of the flowmeter.B. Electrical<ul style="list-style-type: none">a. Variable Frequency Drive? Need additional filtering and improved grounding.b. Marginal Connection (particularly for remote units)? Rewire to insure good contacts.C. Moisture intrusion? Use leak tight fittings and keep the covers tight.
2. Pulse Output Incorrect	Check settings of pulse output – See Appendix 1
3. Meter Reads Zero	Did it ever work? <ul style="list-style-type: none">A. Blown coil drive? Return for repairB. Conductive coating? Clean sensor.
4. Blank Display	Module requires replacement
5. Display is turning black around edges	Temperature is too high inside the enclosure. Relocate the meter or shield against the heat source. Continuing to power the meter in this condition will permanently damage the display.

6. Display is difficult to read

Improve the lighting conditions if ambient light is dim. Remove large cover and adjust the pot directly above the display for best contrast while viewing from the intended viewing angle.

If the above steps fail to correct the problem, call the factory. Please have the following information available when you call:

- Description of the problem. (Display, current output, totalizer/frequency, all of the above.)
- When does the symptom occur or repeat?
- What are the flow rates, the orientation of the meter in the pipeline, environmental conditions, output loads on the meter, pipe material and grounding technique?
- How did you verify the discrepancy?

Contact Technical Support (800) 800-FLOW for additional assistance

7.3 Electronics Module Replacement

To remove the electronics module:

- 1) Unscrew the rear, blind, cover.
- 2) Disconnect the battery and DC power, if applied.



Do not remove Electronics Module while power is applied. Disconnect Power before proceeding.

- 3) Unscrew the front enclosure cover and remove the two screws holding the module in place. Unplug the power cable and ribbon cable. The module can now be removed.

METER ELECTRONICS IS SUPPLIED AS A SINGLE UNIT AND CONTAINS NO USER SERVICEABLE PARTS.

- 4) To place a new module into service, reverse the operation. Note the flash memory contains the calibration data and thus no parameters or data need to be updated when the module is replaced.

7.4 Replacing the flash memory

To replace the flash memory chip that contains the calibration information remove the back, blind cover, disconnect the battery and power and remove the flash memory chip from the I/O board. Once the Flash memory is replaced, the battery and power wire can be reconnected.

7.5 Replacing the Battery

The battery is a long-life battery up to five years. When, however, it is time to change the battery, it is a straight forward operation:

- 1) Unscrew the rear, blind, cover.
- 2) Disconnect the battery
- 3) Pull the battery from the battery clip
- 4) Put the new battery into the battery clip.
- 5) Connect the battery wire to the IO board.
- 6) Screw on the rear, blind cover.

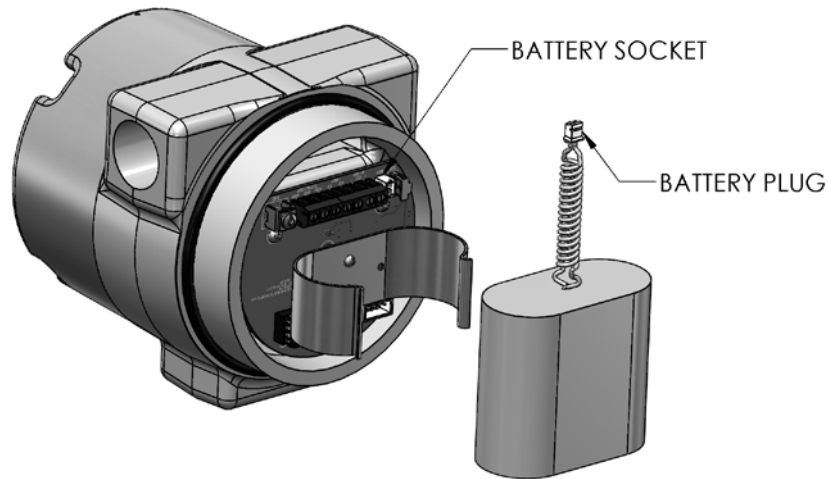

8.0 Replacement Parts List

The following is a list of the spare parts available for the Sparling BlueWater flowmeter.

Description	Sparling Part Number
Electronics Module	568212
I/O Board	568011
Programmed Flash Memory Chip	156128
Battery	BWBAT001

Appendix 1: Programming the BlueWater Flow Meter

The BlueWater flowmeter is shipped with battery connected, ready to use. There is no set up needed other than the correct installation as described in Section 3. However, the setup of the meter should be verified after installation.

Displaying the setup of meter and changing parameters of the meter is achieved using the Mag-Command magnetic probe furnished with each meter. (It can also be programmed with any high strength magnet). Below the LED display are located two magnetically operated Hall effect switches. The switch on the left side, labeled "YES", is the "YES" command and the switch on the right, labeled "NO" is the "NO" command. The switches are activated by waving the magnetic probe over the appropriate switch.



This interface is configured to be a conversation with the meter, using 'YES' and 'NO' to make changes to menu items and to move through the menu items.

There is no need to open the enclosure to communicate with the meter. These switches are the only controls required to select and change parameters on the BlueWater.

When data is required, the cursor will be positioned under the first character. A "NO" answer will cause the next valid character to be displayed in turn. A "YES" answer accepts the displayed character or digit and moves the cursor to the next position.

A1.1 Show Meter Data

To select the INFO, select 'NO' until the INFO menu item is highlighted. Select INFO by answering 'YES' when the INFO menu item is highlighted. The INFO is split into two screens.

A1.1.1 Show Meter Data - Screen 1

The first screen displays the following data:

- 1) Model:** This has the full model code for the meter. Sparling's Model Code includes a full designation of the meter. Model codes are in the following format:

FM676-SS-TPC-D where:

SS – Nominal Size of the meter:

03 - 3"

04 - 4"

06 - 6"

08 - 8"

10 - 10"

12 - 12"

14 - 14"

T – Transmitter Mounting: 0 = Integral NEMA-4X Enclosure

P – Power: 1 = Battery / 8 – 36 VDC

C – Output Communications: 0 = Pulse Output

D – Datalogger: 0 = No Datalogger

1 = Datalogger

- 2) Serial Number:** The unique serial number assigned to the meter. Note all BlueWater flowmeter serial numbers start with 'B'.
- 3) Size:** The Nominal size of the meter
- 4) Firmware:** The firmware revision level
- 5) Tag Number:** Tag number assigned to this meter, if any

The following is an example screen showing this information.

MODEL: FM676-03-0-10-0
S/N: B123452018
SIZE: 3 INCH
FIRMWARE: BW-1.0
TAG: TEST
NEXT

Show Meter Data – Screen 1

A1.1.2 Show Meter Data - Screen 2

The Second screen displays the following data:

- 1) Totalization Registration:** Pulse registration and units of totalization

2) **Pulse Width:** Shows if pulse output is 'OFF' or if on, pulse width selected 12.5 ms, 25 ms, 50 ms and 100 ms.

The following is an example screen showing this information.

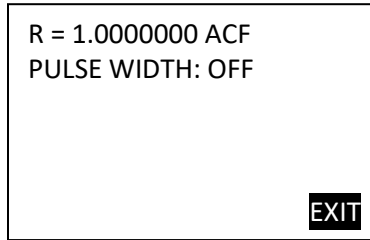

Show Meter Data – Screen 2

A1.2 Configuration of BlueWater Flowmeter

There are certain parameters that can be modified and set in the field. To enter the configuration screens, navigate to the menu screen and when asked for password, enter the password. Note this password is available to authorized dealers only - please contact your authorized Sparling Distributor for further information.

Once in the menu screens, the following options will be available. Use the 'NO' command to move the cursor to the next menu selection:

- 1) **DATE:** Enter this menu to set the Date and Time.

- 2) **RATE:** Enter this menu to set the units of the Rate measurement and Flow direction.
 - a. The options for **Rate** are:
 - i. GPM (Gallons per minute) (this is the default)
 - ii. LPM (Liters per minute)
 - iii. CFS (Cubic Feet per Second)
 - iv. LPS (Liters per Second)
 - v. M3H (Cubic Meters per Hour)
 - vi. MGD (Millions of Gallons per Day)
 - vii. F/S (Feet per Second)
 - viii. L/S (Meters per Second)
 - ix. USR (User units - If this is selected, then a custom conversion factor must be entered).
 - b. The options for **Flow Direction** are:
 - i. FWD – Forward, in the direction of the flow arrow on the sensor housing
 - ii. REV – Reverse

- 3) **TOTAL:** Enter this menu to change the units for totalization on the screen, enable and set parameters for pulse and set totalizer to total in forward , forward and reverse or net directions.
 - a. The options for **Total Unit** are:
 - i. ACF (acre feet) (this is the default)
 - ii. GAL (gallons)
 - iii. CFT (Cubic Feet)
 - iv. LTR (Liters)
 - v. M3 (Cubic Meters)
 - vi. USR (User units - If this is selected, then a custom conversion factor must be entered).
 - b. The options for **Pulse Width** are:
 - i. Off – this is the option to turn pulse output off
 - ii. 12.5 ms
 - iii. 25 ms
 - iv. 50 ms
 - v. 100 ms
 - c. **R** – enter registration for the totalization

- d. The options for **MODE** are:
 - i. Forward – to total in the forward direction only
 - ii. Forward and Reverse – to total in forward and reverse independently
 - iii. Net to total forward, net reverse.
- 4) **TAG**: Use this menu selection to input a tag number, if any.
- 5) **PASSWORD**: Use this menus selection to set the password.
- 6) **SMULATE**: Use this menu to start and stop the simulation mode that allows the display to show a dummy flow rate and related total.

IDS-676-DL Rev 180510
Sparling Instruments, LLC
4097 N. Temple City Blvd.
El Monte CA 91731
Copyright 2018 Sparling Instruments, LLC